

Nancy Page Club Quilt of Many Stars

Block 2

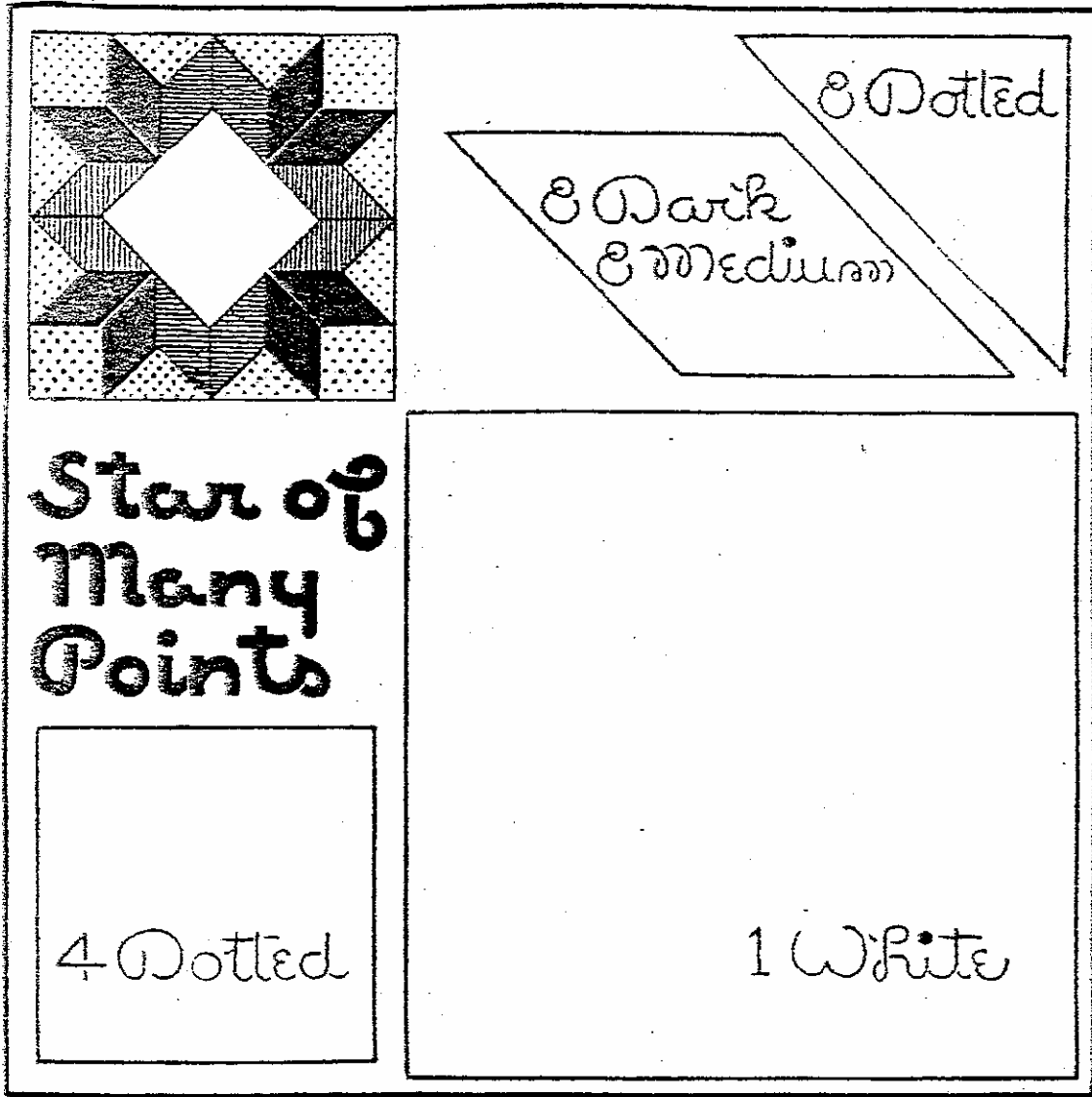

The diagram shows a quilt block layout with the following components:

- Star of Many Points:** A central star-shaped block composed of various patterned fabrics.
- Dark and Medium:** A large triangular fabric piece labeled "3 Dark" and "3 Medium".
- White:** A large square fabric piece labeled "1 White".
- Dotted:** A small square fabric piece labeled "4 Dotted".

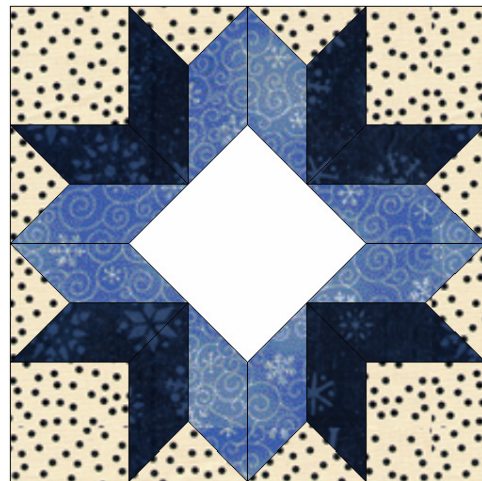

Nancy Page Club Quilt of Many Stars Block 2

Most of this block can be rotary cut and hand or machine pieced.

The finished size of this block is 9" (9 1/2" unfinished)

Cutting:

- Dot Background:** Cut four 2 3/4" squares
Cut two 3 1/2" square and cut diagonally
both ways to yield eight triangles.
- Dark Blue:** Cut four A diamonds
Cut four A diamonds reversed
- Medium Blue:** Cut four A diamonds
Cut four A diamonds reversed
- Light Background:** Cut one 3 5/8" square

Piece the block together as pictured below -

Sew dark blue and medium blue diamonds together in 4 units that looks like this -



Add the dot background triangles and squares to each unit.



Sew a unit to each side of the center square. Complete the block by sewing the seam between the two medium blue diamonds.

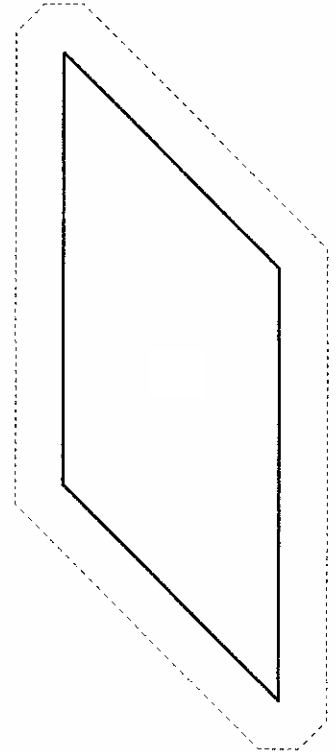
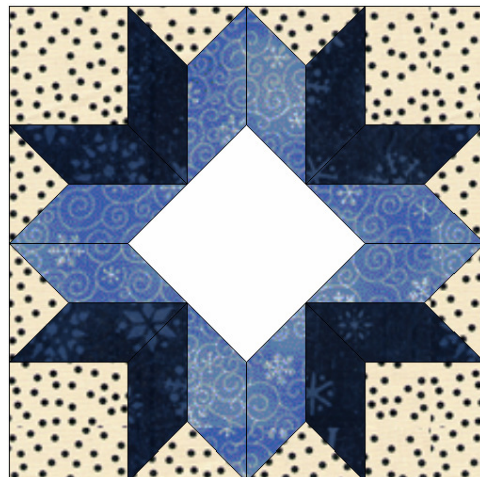

BLOCK 2: STAR OF MANY POINTS

After the tiny stars which had appeared in last week's installment of this beautiful quilt the club members breathed a sigh of relief when they saw this "Star of Many Points."

"I'll wager we can name one point of this star which you never thought of, Nancy." "Is that so, what is it?" "The biggest point in its favor is the large size of the pieces and the small number of them in the star."

Nancy grinned. "I did give you a pretty stiff assignment in those joining and border stars, didn't I?" But you can spend the next six weeks making them for we won't be ready for all of them until we have finished the big stars which make up the center of the quilt.

"You do like this star of many points on its own accord don't you?" The members agreed with her that they did. For the star they used the dark blue and white print, the medium blue and white print, the dotted background material and the plain white.

When Nancy talks of the polka-dot material she is referring to some background material which may or may not be polka-dotted. One member was using a white ground sprigged with a tiny, tiny flower. Another member had a white material with an infinitesimally small ring in black on it. Another had chosen a white background liberally besprinkled with stars.

Whatever the material chosen may be, the effect to be desired is that of an old-fashioned material such as our grandmothers used.

The members clipped the picture and directions from the paper. They transferred the design on lightweight cardboard. They pasted the original in the Nancy Page scrapbook. After they had cut the cardboard patterns they laid these on the material. With a sharp pencil they drew around the outline of the pattern. Then they cut the material with a quarter inch allowance on all sides beyond the pencil mark. This mark gave them the exact place for their seaming stitches. These stitches were small. They were taken with a fine needle and a number 60 thread. The thread was knotted in a firm small knot and the seam was finished with two or three small back stitches.

The seams started and ended in one-quarter inch from both ends and the edges of the pieces. The Nancy Page quilt club members knew that each block was pressed after being pieced. Then the block was laid away in a box to wait the joyful and exciting day when the blocks would all be put together with the sashing and joining Stars to make the quilt top.



Sentimental Stitches™

4759 Boyd NE / Grand Rapids MI 49525
Phone: (616) 361-9255 / www.sentimentalstitches.com

Copyright 2010 Sentimental Stitches™ Inc.